

30990 A

Name :

Reg. No:

FIFTH SEMESTER B.TECH (ENGINEERING) DEGREE EXAMINATION, OCTOBER 2012

ME 09 505 – MECHANICS OF MACHINERY
(2009 Scheme)

Time : Three Hours

Maximum : 70 Marks

(5×2 marks =10 marks)

1. What is a kinematic pair? How can it be classified?
2. Name the different motions that a follower can have.
3. What do you mean by involute profile? Shows that gear teeth with involute profile satisfy the law of gearing.
4. What are the advantages of epicyclic gear train?
5. What do you mean by degree of freedom of a mechanism? Explain Grubler's equation for determining degree of freedom of a mechanism.

PART-B

(4 × 5 = 20 Marks)

1. Explain the procedure to draw velocity polygon of a slotted lever mechanism.
2. What are straight line motion mechanisms? Name the different types of mechanisms used for straight line motion.
3. Describe the various factors which govern the choice of profile.
4. Compare the properties of involute profile and cycloidal profile teeth.
5. Name the different types of gear train and give the examples where each of them is used.
6. Explain the three position synthesis of a slider crank mechanism.

PART-C

(4×10 marks =40 marks)

1. In a four-bar mechanism PQRS, the link PS is fixed. The length of the links are PQ=25mm, OR=85mm, RS=50mm and PS=80mm. The crank PQ rotates at 10 rad/s clockwise. Sketch the mechanism and draw the velocity and acceleration diagram when the link PQ makes 60° with link PS. Find the angular velocity and angular acceleration of links OR and RS.

(OR)

2. A mechanism as shown in figure.1 has the following dimensions: $O_1A = 60$ mm;
 $AB = 180$ mm; $O_2B = 100$ mm; $O_2C = 180$ mm and $CD = 270$ mm. The crank

$O_1C = 180$ mm and $CD = 270$ mm. The crank O_1A rotates clockwise at a uniform speed of 120 r.p.m. The block D moves in vertical guides. Find by instantaneous centre method, the velocity of D and the angular velocity of CD .

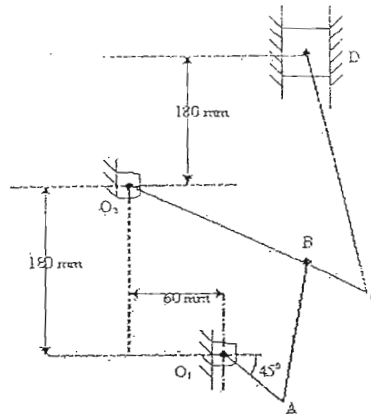

Figure.1

3. Draw the profile of the cam when the roller follower moves with cycloidal motion during outstroke and return stroke, as given below:
- Outstroke with maximum displacement of 40mm during 180° of cam rotation
 - Return stroke for the next 150° of cam rotation
 - Dwell for the remaining 30° of cam rotation

The minimum radius of the cam is 15mm and the roller diameter of the follower is 10mm. The axis of the roller is offset by 10mm towards right from the axis of cam.

(OR)

4. A symmetrical tangent cam with a least radius of 25 mm operates a roller follower of radius 10 mm. the angle of ascent is 60° and total lift is 15 mm. if the speed of the cam is 400 rpm, then calculate:
- The principal dimensions of the cam i.e the distance between the cam centre and nose centre; nose radius and angle of control of cam with straight flank and
 - The acceleration of the follower at the beginning of the lift, where the roller just touches the nose and at the apex of the circular nose.

Assume that there is no dwell between ascent and decent.

5. Two mating spur gear with module pitch of 6.5 mm have 19 and 47 teeth of 20° pressure angle, and 6.5 mm addendum. Determine the number of pairs of teeth in contact and the

angle turned through by the larger wheel for one pair of teeth in contact. Determine also the sliding velocity at the instant (i) engagement commences, (ii) the engagement terminates, and (iii) at the pitch point. When the pitch line velocity is 1.2 m/s.

(OR)

6. An epicyclic gear train consisting of fixed sun gear, B with 50 teeth meshing with a planet gear, C with 40 teeth. The planet gear meshes with a ring gear, D with 60 teeth. Determine the speed of the ring gear when the arm, A which carries the planet gear rotates at a speed of 100rpm clockwise about the sun gear centre axis.
7. Design a slider crank mechanism so that displacement of the slider is proportional to cube of the crank rotation in the interval of $30^\circ \leq \theta \leq 100^\circ$. Assume initial distance of the slider equal to 15 cm and the final distance to be 10 cm.

(OR)

8. Determine the chebyshev spacing for function $y = 3x^3 - 2x$ for $0 \leq x \leq 1$ and specify three precision points. Also find θ_j and Φ_j ($j = 1, 2, 3$) $20^\circ \leq \theta \leq 80^\circ$ and $60^\circ \leq \Phi \leq 190^\circ$.

